

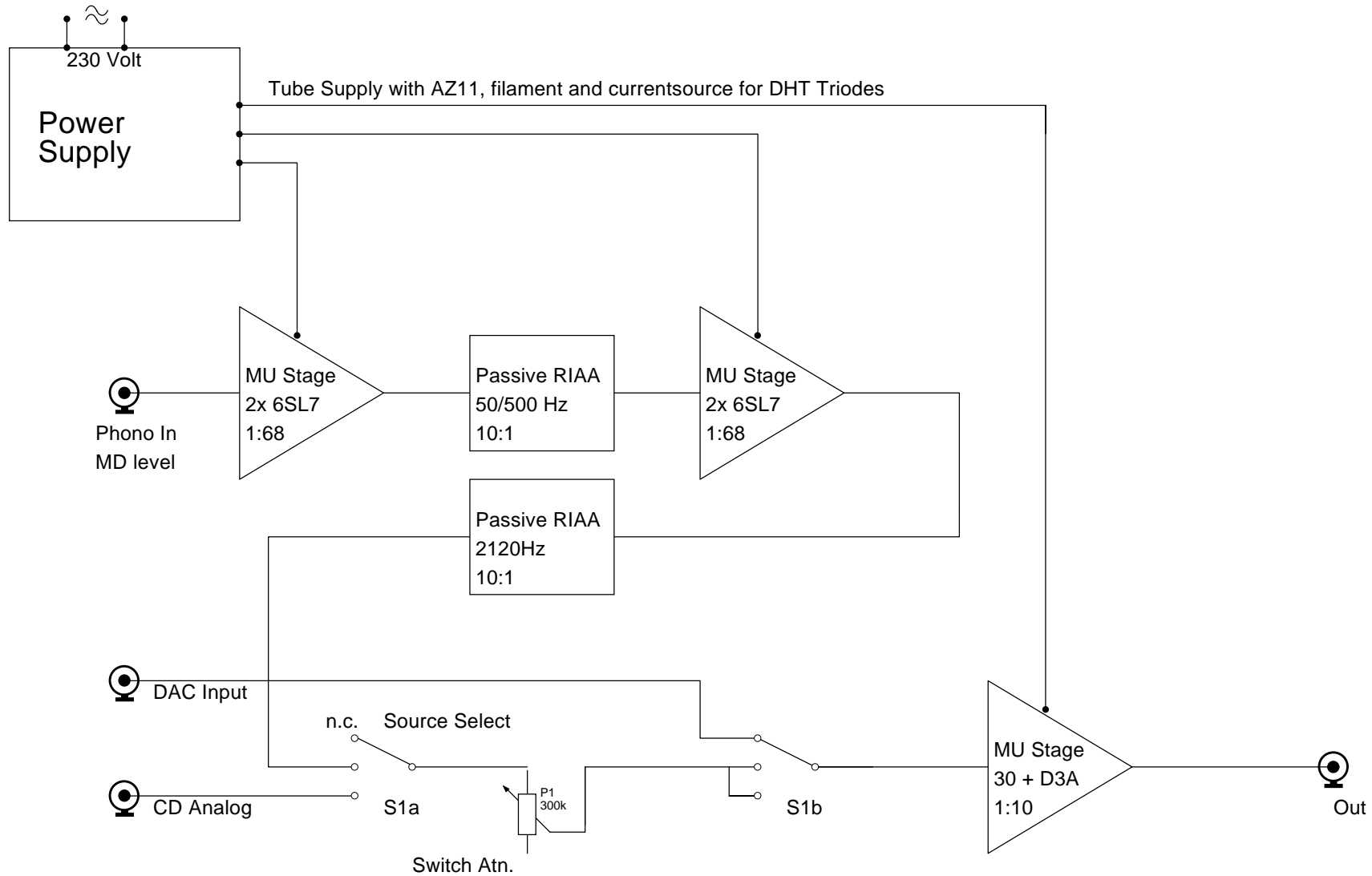

DDPRE 2001

MD Phono
&
Line Tube AMP

www.dddac.de

By Doede Douma
Version 1.1 Update: August 28th 2001



 Analog Ground Line AMP	Only one channel shown, Amp is double MONO	PRE AMP, Block Diagram	
		Update: 26-08-2001	Author: Doede Douma
		Revision: 1.1	Page: 1 # 6

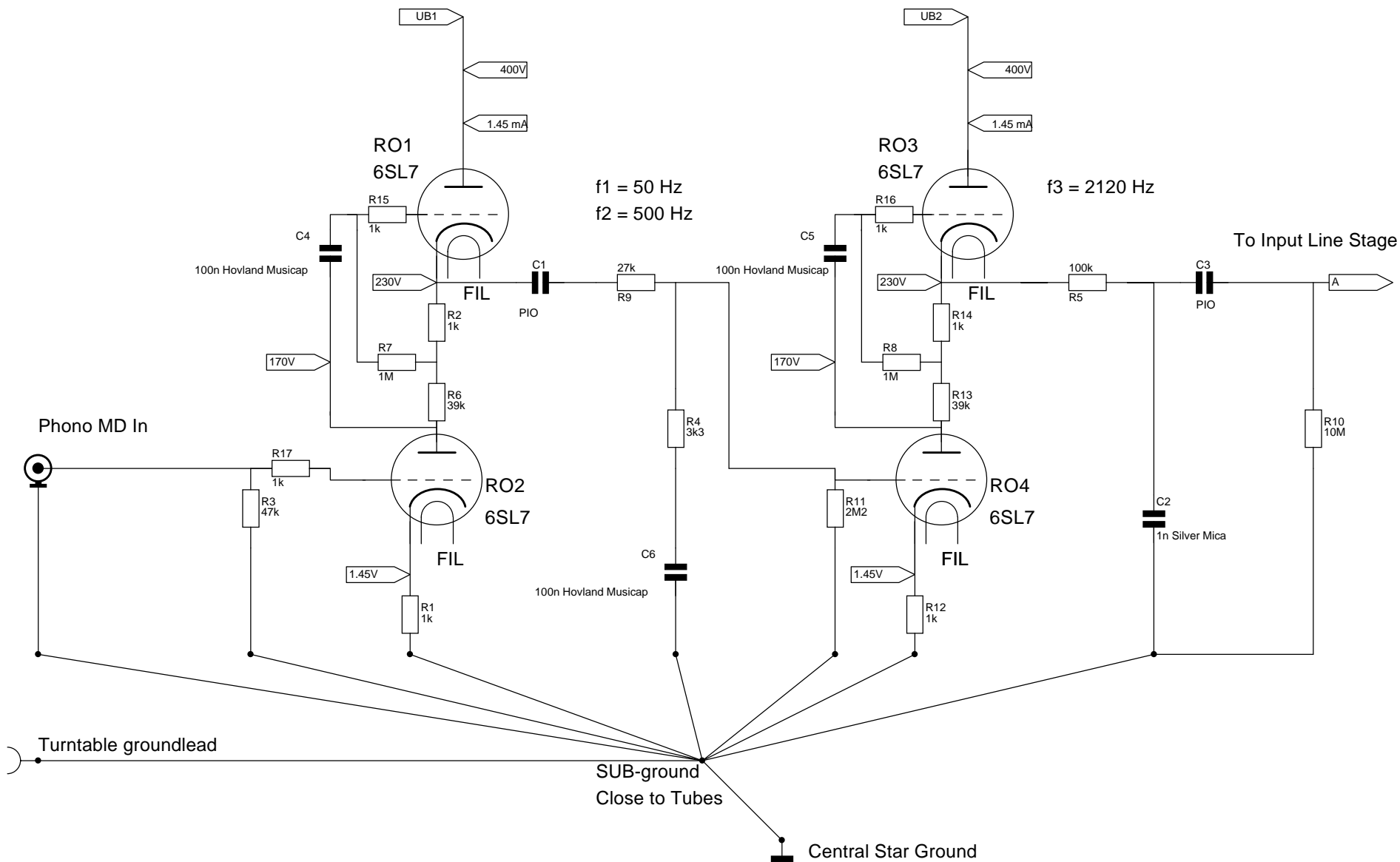

Right Channel identical to Left Channel. All parts x 2
 Total Gain 400x
 Central Star Ground is at first minus from filter capacitor

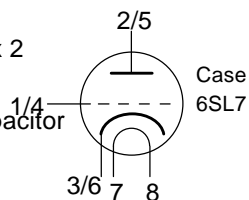

PRE AMP, Phono Stage

Update: 26-08-2001

Author: Doede Douma

Revision: 1.1

Page: 2 # 6

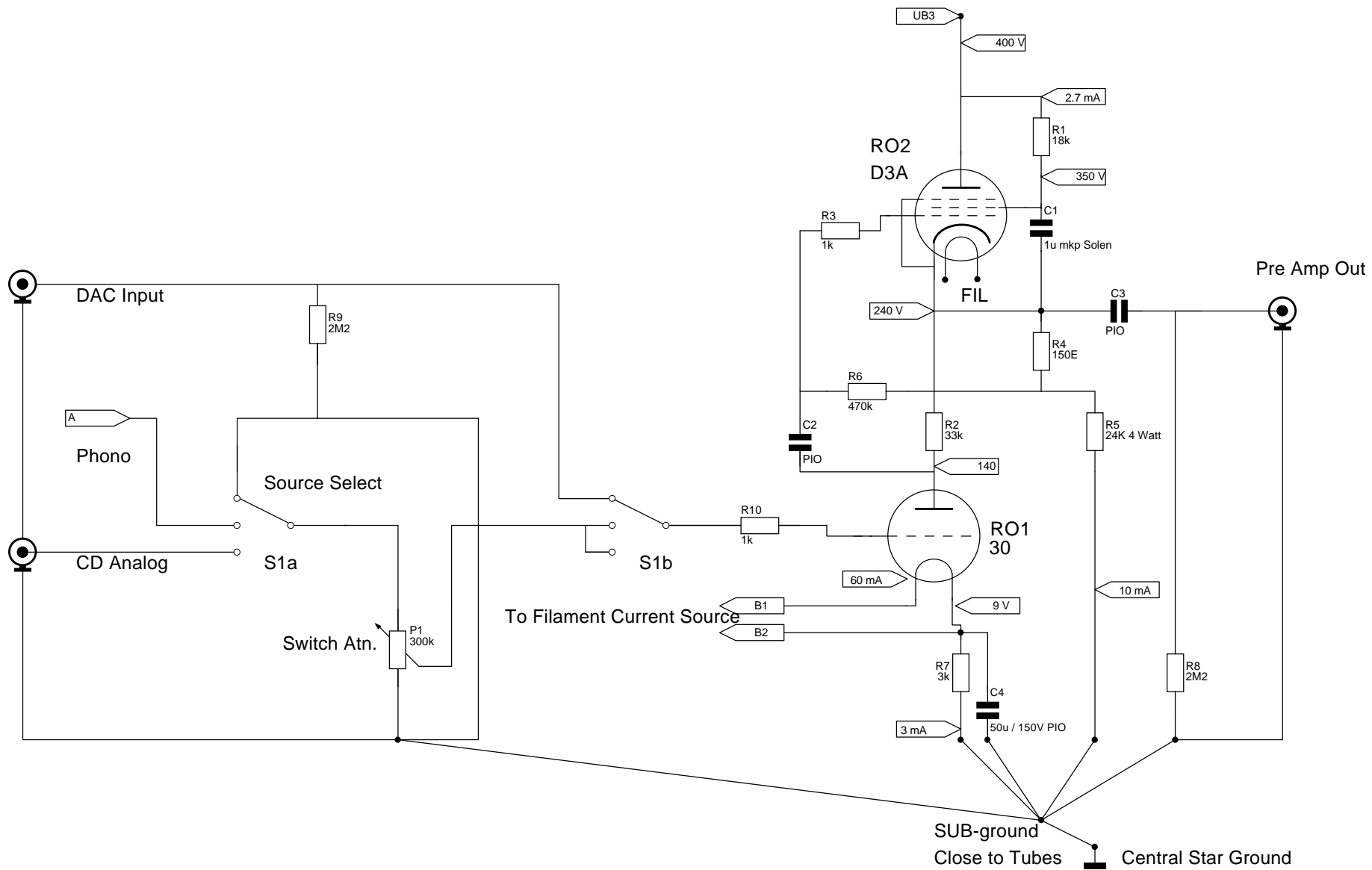

Only One Channel Shown
 Total Gain 10x
 Central Star Ground is at first minus from filter capacitor

PRE AMP, Line Stage

Update: 26-08-2001 Author: Doede Douma

Revision: 1.1

Page: 3 # 6

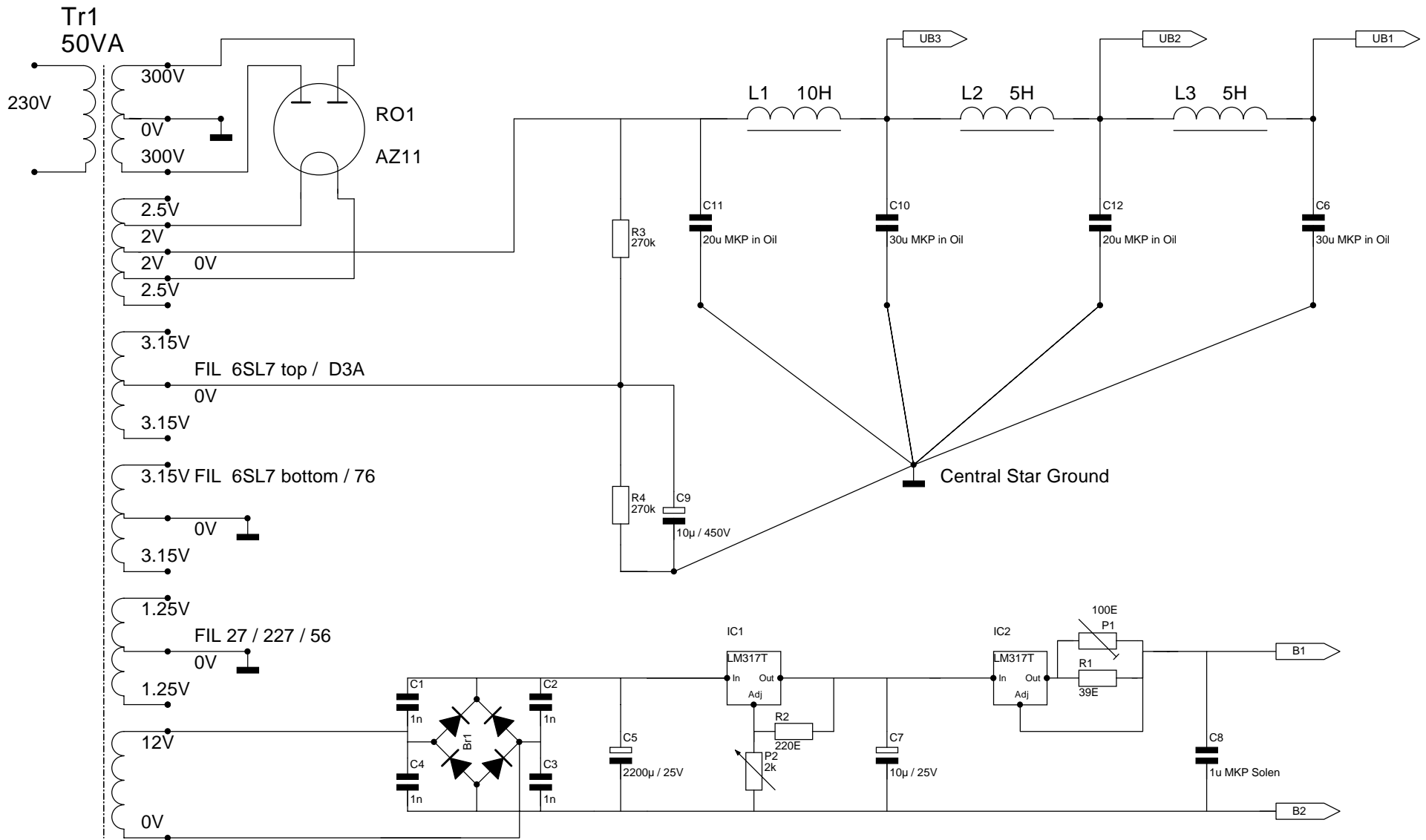

Central Star Ground is at first minus from filter capacitor

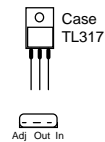
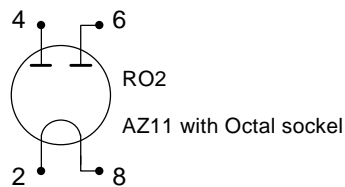

PRE AMP, Power Supply

Update: 26-08-2001

Author: Doede Douma

Revision: 1.1

Page: 4 # 6

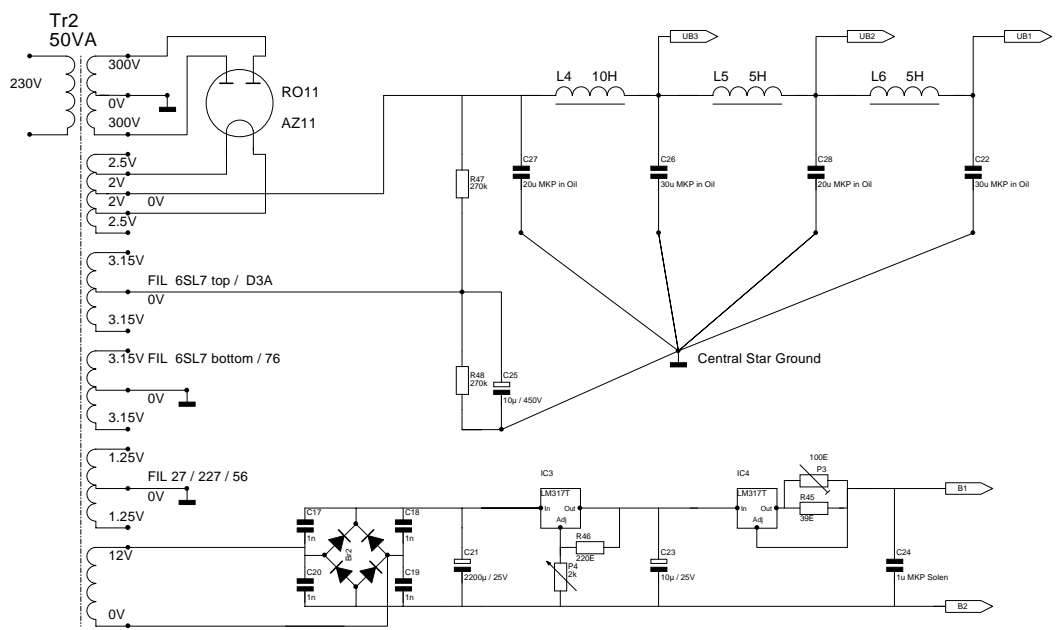
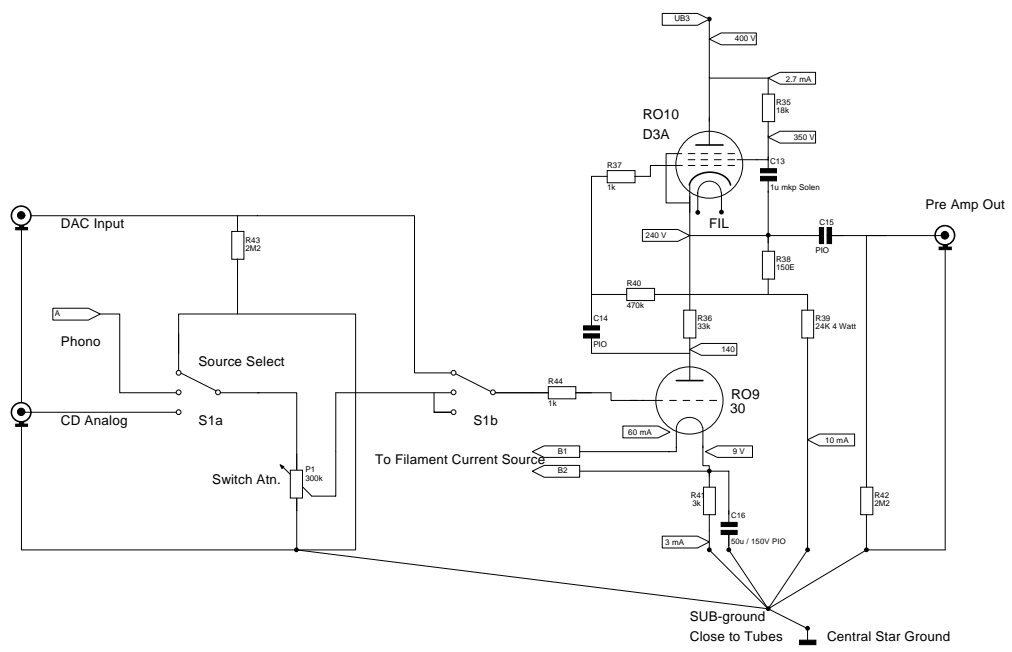
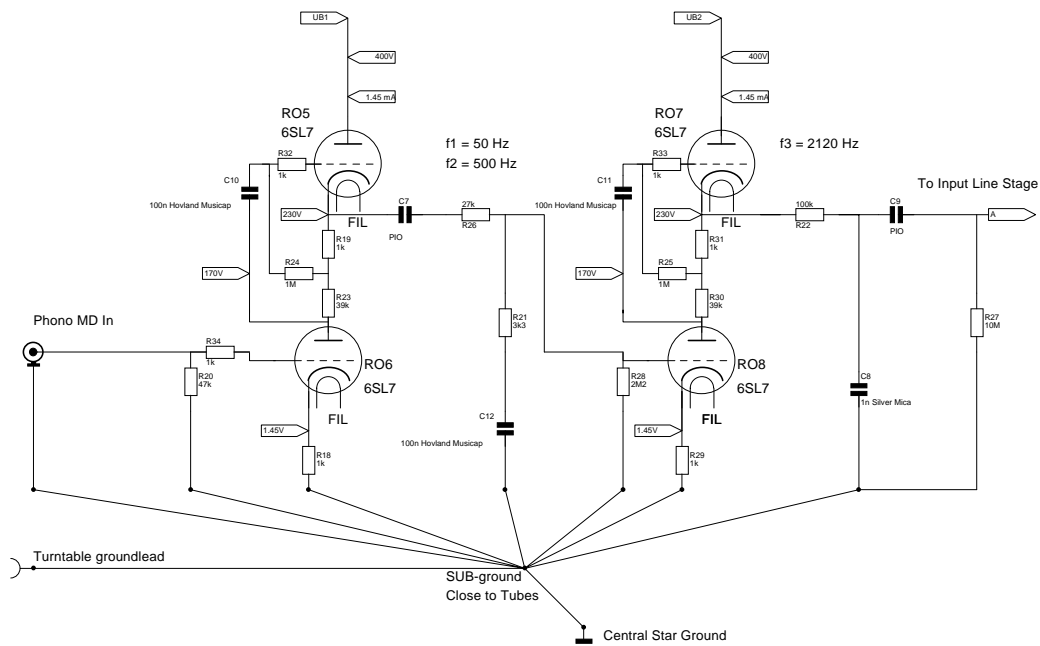

PRE AMP, Phono Stage

Update: 26-08-2001	Author: Doede Douma
Revision: 1.1	Page: 5 # 6

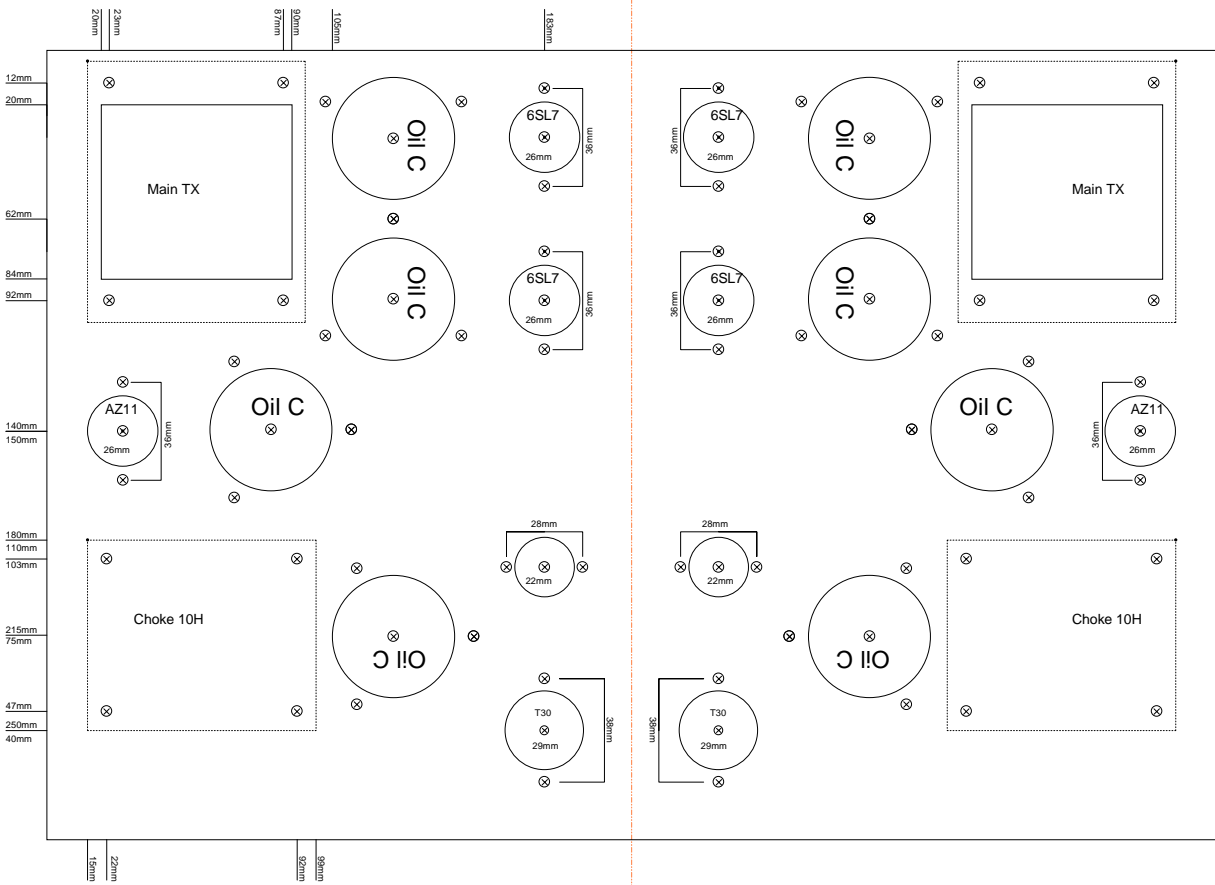

PRE AMP, Case Lay Out

Update: 26-08-2001	Author: Doede Douma
Revision: 1.1	Page: 6 # 6